

PWRPAX-AIR
Multi-Port Power Pack
Operation and Maintenance Manual

www.TorsionX.com

Safety Guide

To use the PWRPAX-AIR Multi-Port Power Pack safely you must follow correct operation guidelines and inspect the equipment regularly. Read and follow all instructions and put on proper personal protective equipment (PPE) prior to use.

UPON RECEIPT OF THIS TOOL, INSPECT THE PACKAGE FOR DAMAGE.

Carefully inspect all components for damage incurred during shipping. If any shipping damage is found, notify the carrier at once. Shipping damage is NOT covered by warranty. The carrier is responsible for all repair or replacement costs resulting from damage in shipment.

Neither TorsionX, nor its distributors are responsible for damage caused by unsafe and/or faulty operations. If a problem arises during use, shut off the power immediately and consult your TorsionX distributor.

ALL OF OUR PRODUCTS MAY HAVE UPGRADES AND MODIFICATIONS WITHOUT NOTICE.

Table of Contents

Warnings	3
PWRPAX-AIR Multi-Port Power Pack.....	4
Hydraulic Couplers	4
Set Up.....	5
Operation	7
Features	7
Warranty	8
Trouble Shooting Guide	9

Warnings

Hydraulic Hose:

- Inspect hose for wear and damage prior to every use.
 - Only use twin line high-pressure hydraulic hoses rated for 10,000 PSI (700 BAR) with at least a 3:1 safety factor.
 - The maximum operating pressure is 10,000 PSI (700 BAR) - Do not exceed 10,000 PSI (700 BAR).
 - Should a hydraulic hose ever rupture, burst, or need to be disconnected, immediately shut off the hydraulic power pack.
 - Never attempt to grasp a leaking pressurized hose with your hands. The force of the escaping hydraulic fluid could cause serious injury.
- Do not let the hose kink, twist, curl or bend so tightly that oil flow within the hose is blocked or reduced.
 - Too small of a bending radius will kink and destroy the high-pressure hydraulic hose.
- Before operating the hydraulic power pack, tighten all hydraulic hose connections with the proper tools.
 - Connections should be tightened securely and leak-free.
 - **Do not** overtighten.
 - Over tightening can cause premature coupler thread failure.
- Shut off the air motor or disconnect air supply before breaking any hydraulic connections in the system.
- **Do not** subject the hose to potential hazards such as:
 - Fire
 - Sharp surfaces
 - Extreme heat or cold
 - Heavy impact
- Hose material and coupler seals must be compatible with the hydraulic fluid.
 - Keep hoses away from contact with corrosive materials such as creosote-impregnated objects and some paints and solvents.
 - Hose deterioration due to corrosive materials can result in premature failure and serious personal injury.
 - Never paint a hydraulic hose.
 - Never paint hydraulic couplers.

PWRPAX-AIR Multi-Port Power Pack

- Do not exceed the maximum hydraulic pressure rating of 10,000 PSI (700 BAR).
- Do not tamper with any internal high-pressure relief valve.
 - Creating pressure beyond rated capacities can result in serious personal injury.
- Before replenishing the hydraulic oil, retract the system to prevent overfilling the pump reservoir.
 - Overfilling can cause personal injury due to excess reservoir pressure created when the wrenches are retracted.

Air Supply:

- **Disconnect the hydraulic power pack from the air supply when performing maintenance or repairs.**
 - If the air supply is compromised or the remote tubing is damaged in any way, replace immediately.
 - If the remote tubing is damaged or leaking, replace or repair immediately.
 - Ensure sufficient air flow available at pressure you will be using.
 - Damaged remote control tubing can cause irregular behavior, inspect tubing carefully.

Hydraulic Couplers

- Never overtighten the hydraulic coupler.
 - Overtightening can cause premature thread failure.
- Check for gaps in the hydraulic coupler.
 - **Gaps can cause a disruption in the flow of hydraulic fluid.**
 - **Gaps will cause the hydraulic torque wrench to not operate.**
- Immediately replace any worn or damaged hydraulic couplers.
- Do not use the hose to move the attached equipment.

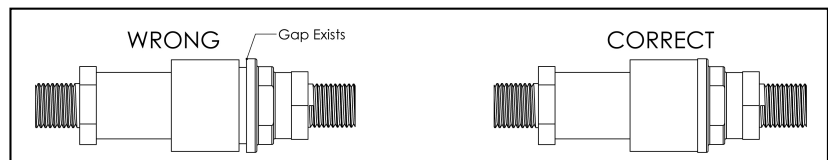

Figure 1

IMPORTANT

WHEN ONLY USING ONE HYDRAULIC TORQUE WRENCH, COVER THE EMPTY HYDRAULIC COUPLINGS WITH DUST CAPS.

USE A STABLE AIR SUPPLY CAPABLE OF 25-35 CFM @ 90-100 PSI, IF SUPPLY IS UNSTEADY IT MAY AFFECT THE PERFORMANCE AND MAY DAMAGE THE HYDRAULIC POWER PACK.

ENSURE FRL ADJUSTED CORRECTLY TO LESS THAN 100PSI AND CONTAINS SUFFICIENT LUBRICANT TYPE DETERGENT SAE#10 AUTOMOTIVE ENGINE OIL OR EQUIVALENT.

Operation Warnings:

- Before performing any maintenance, disconnect power pack from air supply.
- **Do not** permit anyone to stand in front of open hydraulic couplers during operation.
- **Never** exceed the maximum operating pressure of 10,000 PSI.
- **Do not** operate without oil.
- Keep the power pack clean.

Set Up

Hydraulic Oil:

Attention: The power pack has been shipped **without** oil in the reservoir. Only use a high-quality, non-foaming hydraulic oil, that meets the following requirements:

- Cleanliness Level:
 - **ISO 4406:** 17/15/12
 - **NAS 1638:** 6
 - **SAE 749:** 3
- ISO Viscosity Grade:
 - **Cold Climates:** 32
 - **Temperate Climates:** 46
 - **Tropical Climates:** 68

Filling the Reservoir:

1. Place PWRPAX on level surface.
2. Clean the area around the filler cap.
 - a. Any dirt or grime in the hydraulic oil can damage the internal workings of the power pack.
3. Remove the filler cap, and insert a clean funnel.
4. Fill with appropriate hydraulic oil until oil above red dot in sight-glass window.
5. Replace filler cap.
6. Cycle the power pack (with hydraulic torque wrench attached) several times.
7. Retract the hydraulic torque wrench and check the oil level in the power pack reservoir again.
 - a. This will also help eliminate air from the system.

Hydraulic Connections:

1. Inspect all hydraulic twin line hoses, threads and fittings for signs of wear or damage and replace as needed.
2. Clean all hose ends and hydraulic couplers.
3. Connect the twin line hydraulic hose to the hydraulic torque wrench and the power pack, making sure all hydraulic couplers are snug.
4. Jog the power pack several times.
 - a. The power pack is now ready to be put into regular operation.

Adjusting the Hydraulic Pressure:

NOTE: For easy adjustment of the pressure regulating valve always adjust the pressure by increasing to the desired pressure setting.

1. Loosen the locknut on the pressure regulating valve, and back the adjusting knob out a few turns.
 - a. Do so by turning the adjusting knob in a counterclockwise direction. (Figure 2)
 - b. This will decrease the pressure setting to a pressure lower than the desired pressure.

IMPORTANT: NEVER EXCEED 10,000 PSI

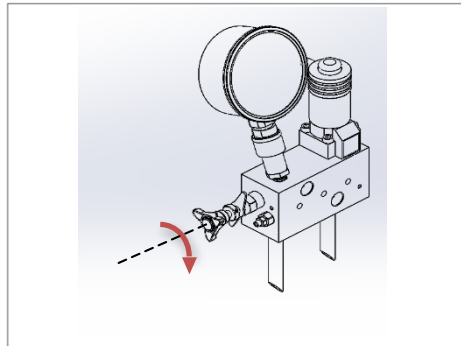
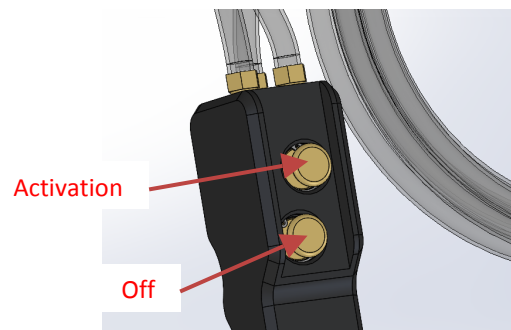

Figure 2

ATTENTION: THE POWER PACK MUST BE COMPLETELY CONNECTED AND THE HYDRAULIC TORQUE WRENCH MUST NOT BE ON THE APPLICATION WHEN ADJUSTING THE PRESSURE.

2. Connect the air supply, adjust the FRL pressure on the 2" gauge to <100 psi and press the activation button momentarily until the pump turns on.
 - a. The activation button the top button on the remote located closest to the hoses.
3. Once you have momentarily pressed and released the top button the power pack should turn and remain on.
 - a. In this condition the power pack will deliver hydraulic oil to the low-pressure port (Port B).



4. Press and hold the activation button (top) to change the power pack to the advance mode.
 - a. The power pack will now deliver hydraulic oil to the high-pressure port (Port A).
5. While holding activation button, slowly turn the adjusting knob in a clockwise direction.
 - a. This will gradually increase the pressure setting.
6. When the desired pressure is reached, release the activation button (top), and then press the off button (bottom) to turn off the power pack.
7. With the power pack off, lock the adjusting knob in position by tightening the wingnut.

IMPORTANT: NEVER EXCEED 10,000 PSI (700 BAR)

Operation

1. Press and hold the activation button on the remote to advance the hydraulic torque wrench.
2. When you hear an audible “Click” from the hydraulic torque wrench, release the activation button.
 - a. The hydraulic torque wrench will automatically retract.
3. When the hydraulic torque wrench is fully retracted, repeat the process until the desired pressure/torque rating is reached.
- To disconnect tools and hoses from system, you must release system pressure.
 - a. To release pressure from system, press both the activation and off buttons at the same time.

Attention: When using a hydraulic power pack for the first time, activate the hydraulic torque wrench prior to putting tool on an application; this will help remove any air from the system.

Features:

- PWRPAX-AIR Multi-Port Power Pack is a three-stage power pack. The pressure relief valve is assembled in the high-pressure port.
- Flow rates for the power pack by stage are:
 - 50in /min in high pressure stage
 - 110in /min in mid pressure stage
 - 625in /min in low pressure stage
- Maximum operating pressure: 10,000 PSI
- The PWRPAX-AIR Multi-Port Power Pack can simultaneously run two or four torque wrenches at the same time.
- Air supply requirements:
 - 25-35 CFM @ 90-100 PSI IDEAL
- Acceptable working temperature: -20 F to 105 F (Select appropriate grade oil)
- Overall dimensions: 18”L x 15.5”W x 20”H
- Weight (w/ oil): 64lbs

Warranty

1. TorsionX guarantees the PWRPAX-AIR Multi-Port Power Pack quality for 12 months from the date of purchase.
2. If any quality issue due to the defects of the materials or workmanship is found within the guarantee period, TorsionX will repair or replace the defective products at TorsionX's discretion.
3. If the equipment is found to be damaged due to negligence, operating the power pack incorrectly, tampering with, or attempting to repair the power pack in part or whole, the warranty is invalidated.

Trouble Shooting Guide

Malfunction	Reason for malfunction	Solution
The power pack does not start.	No air connected.	Connect to air supply.
	Insufficient air supply.	Confirm air supply capability.
	Back pressure was not released.	Release system pressure.
The system has no hydraulic pressure.	The hydraulic couplers are not connected properly.	Tighten or re-install.
	No oil in the tank.	Fill oil.
	Not enough oil in tank.	Fill oil.
	Faulty pressure gauge.	Replace gauge.
The system still has no hydraulic pressure after checking the above.	The hydraulic couplers may have a vacuum lock.	Check hydraulic couplers to hydraulic torque wrench. Inspect couplers to ensure they are completely coupled. Occasionally couplers have to be replaced because the check ball does not stay open due to wear.
Hydraulic couplers are leaking.	The o-ring, is worn or missing in the female hydraulic couplers.	Replace the hydraulic couplers.
The desired hydraulic pressure can not be reached.	The pressure setting for high-pressure relief valve is adjusted too low.	Replace high pressure relief valve.
	Oil is mixed with water.	Replace the oil.
	Pressure relief valve broken.	Replace valve.
	Air may be in system.	Repeat operating the system with no load several times to eliminate air.
	High-pressure relief valve may be loose.	Tighten valve.
	The o-ring for high-pressure relief valve may be worn or missing.	Replace o-rings.
There is a loud noise when the power pack is operated.	The bearing(s) may be worn or broken.	Replace bearing(s).
	Air may be in system.	Repeat operating the system with no load several times to eliminate air.
High-pressure flow is reduced.	Piston or spring may be broken.	Replace piston assembly.
	Hydraulic couplers may be loose.	Tighten hydraulic couplers.
	Oil level may be low.	Fill with oil.
	Oil may be too cold.	Change hydraulic oil to a lighter grade.
	Contamination in oil.	Clean tank and replace oil.