

DO NOT SCALE DRAWING

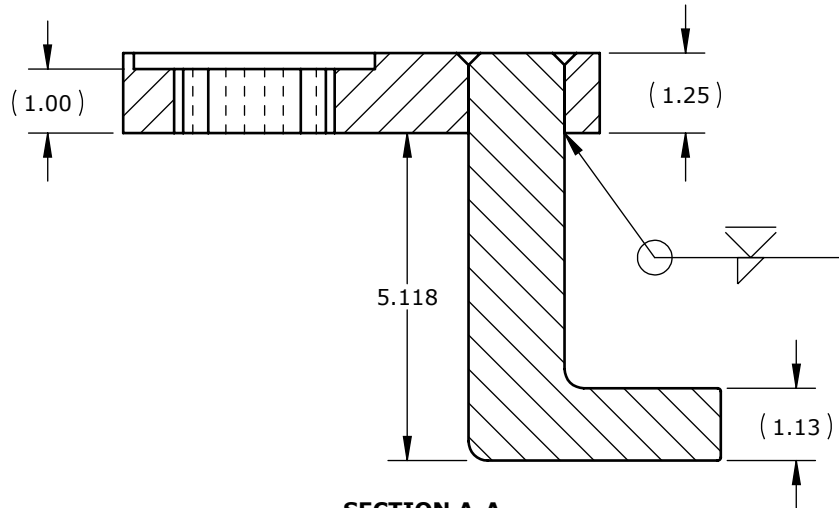
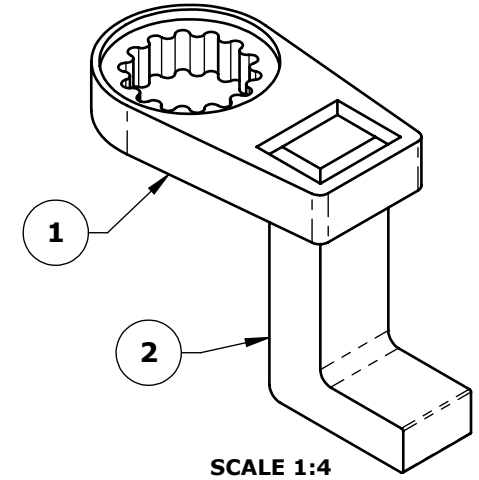
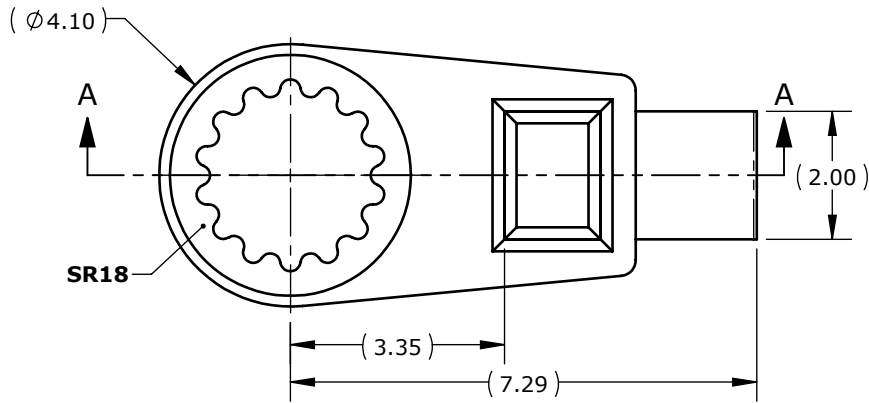

RELEASED FOR FABRICATION
ENGINEERING N.D. DATE 18.04.06

NOTES:

FINISH: YELLOW CHROMATE DIP

ITEM NO.	PART NUMBER	DESCRIPTION	QTY.
1	28406B	BLANK-5.91-1.5/1.5-7.96-1.0-SR18	1
2	28407B	ARM-5.53-3.5-1.5-90	1

REV.	DESCRIPTION	ENG.	E.C.O.	YY.MM.DD
B	28406B WAS A, 28407B WAS A		N.D.	18.04.06

UNLESS OTHERWISE SPECIFIED DIMENSIONS ARE IN INCHES.

TOLERANCES AND SURFACE FINISH:

DECIMAL	LINEAR	ANGULAR	T.I.R.	POSITION	FINISH
.xxxx	±.002	±.05°	.002	Ø.002	32RA
.xxx	±.005	±.10°	.005	Ø.005	63RA
.xx	±.010	±.25°	.010	Ø.010	125RA
.x	±.020	±.50°	.020	Ø.020	250RA
.	±.063	±1.0°	.063	Ø.063	500RA

BREAK EDGES, UNLESS NOTED .016±.003 x 45°
FILLETS, UNLESS NOTED R.010±.003

C.A.D. SCALE 1:3		
MATERIAL		
WEIGHT		
DRAWN	NAME	YY.MM.DD
ENG. CHKD	D.S.	
Q.A. CHKD	A.M.	
MFG. CHKD	P.M.	
ENG. APPD	D.S.	

NEW WORLD TECHNOLOGIES INCORPORATED

THE INFORMATION CONTAINED HEREIN IS THE CONFIDENTIAL PROPERTY OF NEW WORLD TECHNOLOGIES. ANY REPRODUCTION WITHOUT PRIOR WRITTEN CONSENT FROM NEW WORLD TECHNOLOGIES IS STRICTLY PROHIBITED.

NEW WORLD TECHNOLOGIES INCORPORATED
ABBOTSFORD, BRITISH COLUMBIA, CANADA
Phone: 604-852-0405, Fax: 604-852-0269
Website: www.radtorque.com

RA-5.12-3.35/7.29-90-50DX-1.25-SR18

Third Angle Projection

DWG. NO.	REV. SHT.	SZ.
28405B	1/1	A